

KEY NO.	QTY.	PART NO.	DESCRIPTION	OEM	OEMNumber	REMARKS
1	1	5010297	MULTIGRIP JAW, LEFT, ID, 1.5 H, 45-DEG			FABRICATED
2	1	5010298	MULTIGRIP JAW, RIGHT, ID, 1.5 H, 45-DEG			FABRICATED
3	2	5001260	CROSS-PIN, SOFTJAWS [ID]	VERSABUILT		FABRICATED
4	6	5000803	RETAINING RING, EXTERNAL 1/4" DIA.	McMASTER-CARR	97431A300	PURCHASED
5	2	5000808	SPRING, 0.480D X 0.045W X 1.25L	McMASTER-CARR	9657K336	PURCHASE

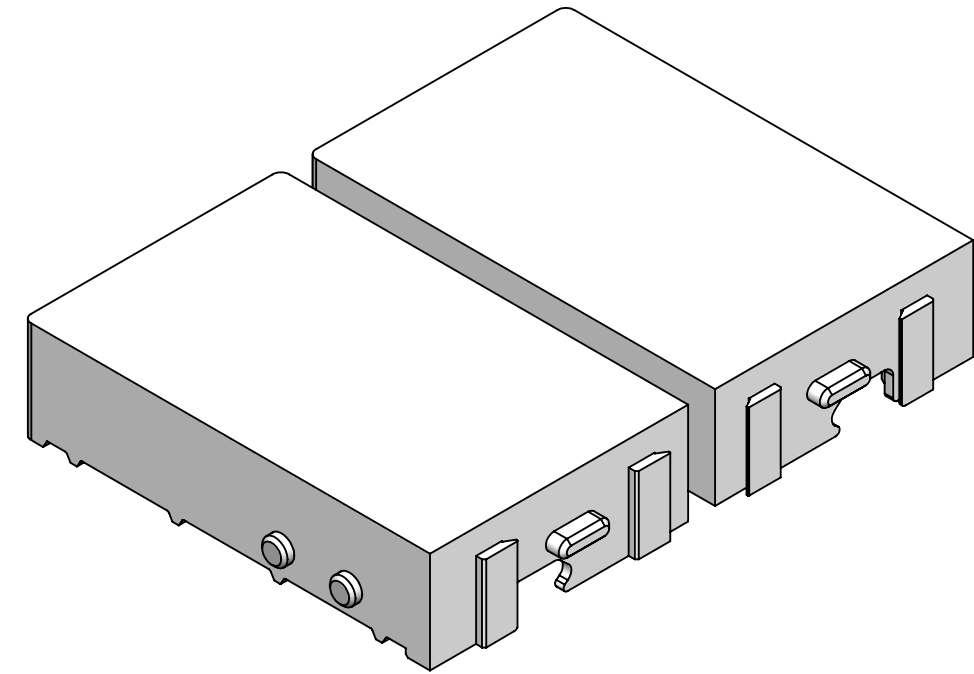
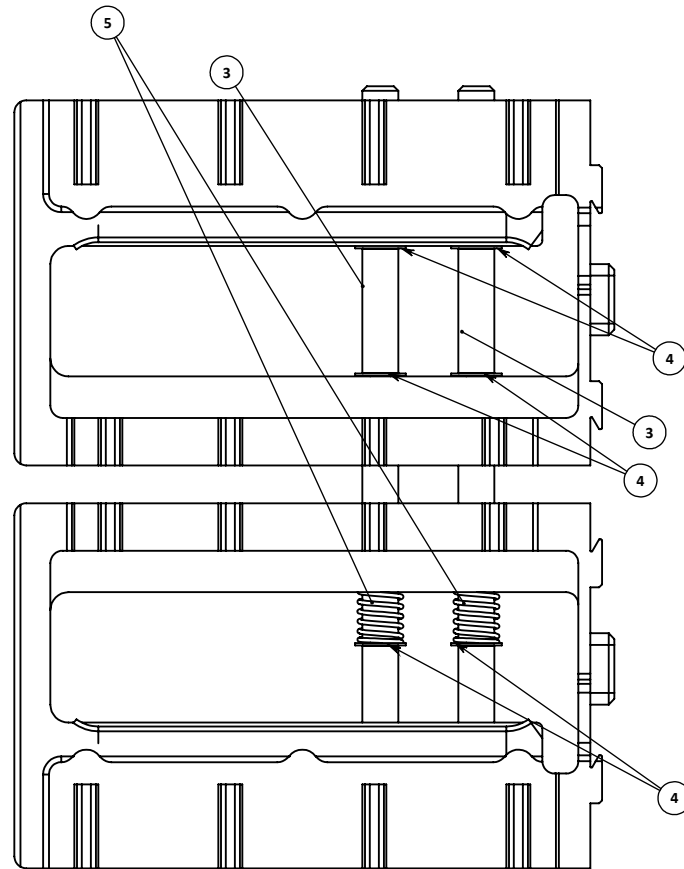
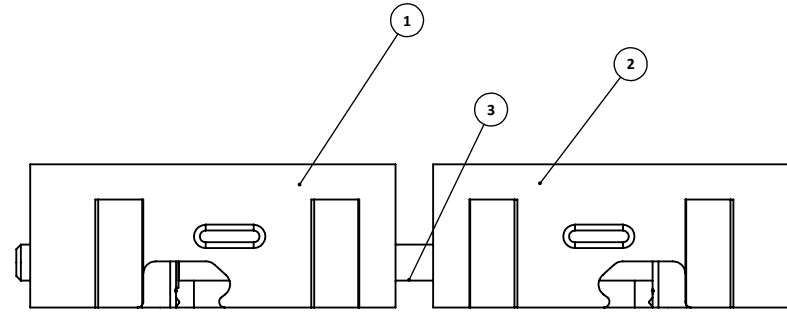
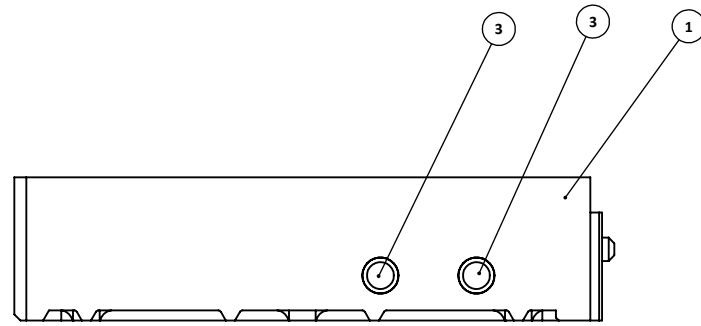

REMARKS	ASSEMBLY
UNITS PRIM./[SEC.]	IN./[mm]
EQUIPMENT NO.	
PART FINISH/COLOR	BY PART
PART/ASSY WEIGHT	5.22 lbs.
THIRD ANGLE PROJECTION	
INTERPRET GEOMETRIC TOLERANCING PER ASME Y14.5-2009 TOLERANCES UNLESS OTHERWISE SPECIFIED FRACTIONS ± 1/32 in DECIMALS imperial metric X.X ±.030 in ±.75 mm X.XX ±.010 in ±.25 mm X.XXX ±.005 in ±.125 mm ANGLES ±.5° ROUGHNESS 125 µin 3.2 µm BREAK ALL SHARP EDGES DIMENSIONS UNLESS OTHERWISE SPECIFIED ARE IN INCHES, [] ARE IN MM DIMENSIONS (X) ARE REFERENCE DO NOT SCALE THIS DRAWING	
DESIGNED BY	BTB 12/3/2021
DRAWN BY	BTB 12/3/2021
CHECKED BY	
APPROVED	

**12000 W FRANKLIN RD
BOISE, ID 83709**

CONFIDENTIAL

THESE DESIGNS AND DRAWINGS, INCLUDING ALL INFORMATION CONTAINED HEREIN,
ARE THE EXCLUSIVE PROPERTY OF VERSABUILT
NO COPY OR REPRODUCTION MAY BE MADE WITHOUT WRITTEN APPROVAL.

MULTIGRIP JAWS

MULTIGRIP JAWS, ID, 1.5H, 45-DEG

SIZE	SCALE	DRAWING NO.	SHEET NO.	OF	REV.
B	1:2	5010301	1	1	A

REV.	DCO #	DESCRIPTION	DATE	BY/CHK./APP.
A		INITIAL RELEASE	12/03/2021	BB
01		INITIAL RELEASE	12/03/2021	BB

PART NO. 5010301 USED ON: ID JAWS